

Product Information Report

Torque Information for Hydraulic Adapters



Overview

The key to making leak-proof connections with hydraulic couplings is to tighten the couplings properly at the time of installation. An over-tightened coupling may be just as likely to leak as an under-tightened coupling and may result in over-stressing and/or cracking.

The torque values in the following tables give minimum and maximum torque recommendations. The minimum value will create a leak-proof seal under most conditions. Applying torque values greater than the maximum recommendation will distort and/or crack the fitting. Values listed in SAE J514 are for qualification testing only and should not be used as the basis for setting up torque values for a production environment. These need to be established based on the coupling manufacturer's recommendations.

When tightening couplings, make sure that the hose does not twist on the adapter. Twisting will shorten hose life and scar the sealing surfaces of swivel-type couplings (JIC 37°, 45°, etc.), which can create leaks. For straight couplings, use a torque wrench on the hex and/or swivel nut and a standard box wrench on the stem hex. Bent tube couplings can be restrained by holding onto the ferrule.

Torque Adjustments



When a crowfoot wrench is used with a torque wrench, adjustments to the torque readings must be made to avoid over-tightening.

As shown below, the distance 'E', from the center of the drive socket to the center of the crowfoot, must be added to the torque value reading.

The following equation can be used to make these adjustments:

Actual Torque = $(E + L) \div L$ (torque wrench reading) where:

L is in inches, feet or meters

E is in inches, feet or meters

Torque is in lb.-in., lb.-ft. or Newton-Meters

Example: Torque Wrench Reading = 45 lb.-ft.

E = 1.5"

L = 12"

Actual Torque = $[(1.5 + 12) \div 12] * 45 = 50.6$ lb.-ft.

This example shows that the actual torque is approximately 10% higher than the reading indicates. All torque recommendations are based on dry threads. If oil or thread sealant is used, the maximum recommended torque values could be decreased by as much as 25%. We recommend lubricating all O-rings prior to insertion into flange heads and O-ring face seal grooves. This will minimize the possibility of nicking the O-ring when it is installed.

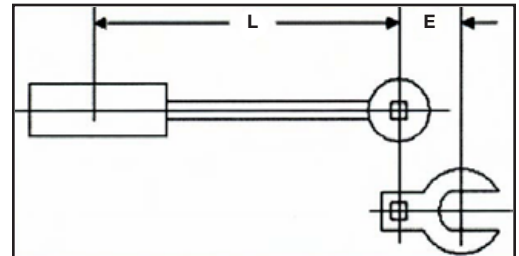

Coupling and Adapter Torque Recommendations

Dry NPTF (Tapered) Pipe Threads

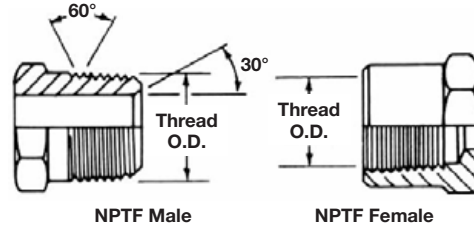

Dash	Size (Inches)	Ft.-Lbs.	Newton-Meters
-2	1/8	20	25
-4	1/4	25	35
-6	3/8	35	45
-8	1/2	45	60
-12	3/4	55	75
-16	1	65	90
-20	1-1/4	80	110
-24	1-1/2	95	130
-32	2	120	160

The torque values obtained from tightening pipe threads can vary considerably depending on the condition of the threads. Adequate sealing can occur at values much lower than the maximum values listed in the chart. However, the minimum torque values must be used to obtain adequate sealing.

37° and 45° Flare, 45° Inverted Flare

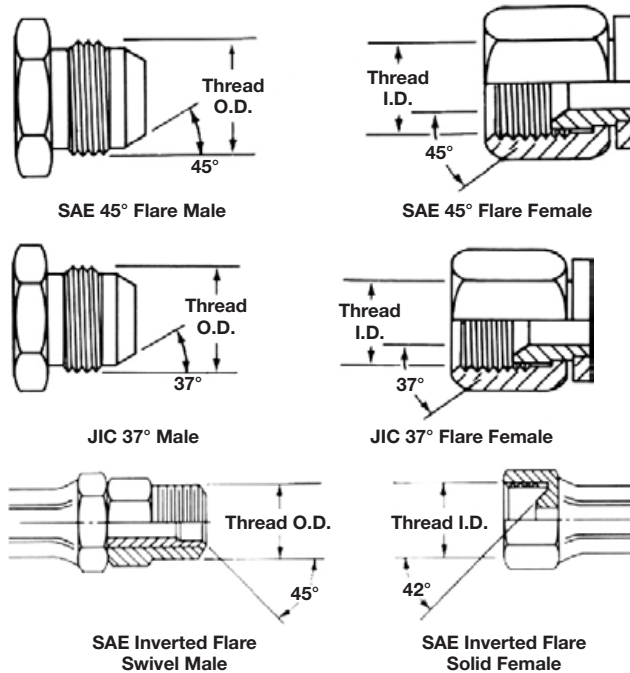

Dash	Size (Inches)	Steel				Brass			
		Ft.-Lbs.		Newton-Meters		Ft.-Lbs.		Newton-Meters	
		Min.	Max.	Min.	Max.	Min.	Max.	Min.	Max.
-4	1/4	10	11	13	15	5	6	7	9
-5	5/16	13	15	18	20	7	9	10	13
-6	3/8	17	19	23	26	12	15	17	20
-8	1/2	34	38	47	52	20	24	28	33
-10	5/8	50	56	69	76	34	40	46	55
-12	3/4	70	78	96	106	53	60	72	82
-16	1	94	104	127	141	74	82	101	111
-20	1-1/4	124	138	169	188	75	83	102	113
-20	1-1/2	156	173	212	235	79	87	107	118
-32	2	219	243	296	329	158	175	214	237

**Coupling and Adapter
 Torque Recommendations
 (cont.)**

SAE O-Ring Boss

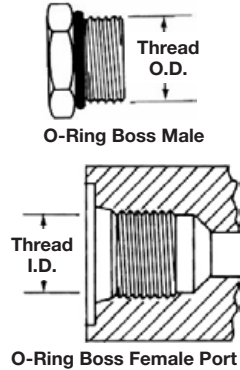

Size		Working Pressures 4,000 PSI (27.5 MPa) and Below				Working Pressures Above 4,000 PSI (27.5 MPa)			
Dash	Fractional (Inches)	Ft.-Lbs.		Newton-Meters		Ft.-Lbs.		Newton-Meters	
		Min.	Max.	Min.	Max.	Min.	Max.	Min.	Max.
-3	3/16	—	—	—	—	8	10	11	13
-4	1/4	14	16	20	22	14	16	20	22
-5	5/16	—	—	—	—	18	20	24	27
-6	3/8	24	26	33	35	24	26	33	35
-8	1/2	37	44	50	60	50	60	68	78
-10	5/8	50	60	68	81	72	80	98	110
-12	3/4	75	83	101-1/2	113	125	135	170	183
-14	7/8	—	—	—	—	160	180	215	245
-16	1	111	125	150	170	200	220	285	380
-20	1-1/4	133	152	180	206	210	280	285	380
-24	1-1/2	156	184	212	250	270	360	370	490

For Flat-Face O-Ring Seal

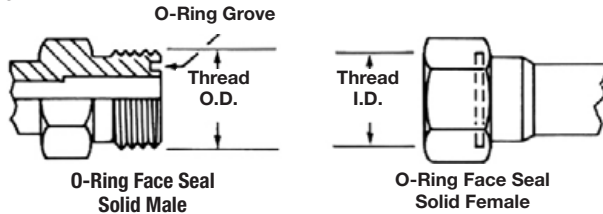

Size		Ft.-Lbs.		Newton-Meters	
Dash	Fractional (Inches)	Min.	Max.	Min.	Max.
		-4	1/4	10	12
-6	3/8	18	20	24	27
-8	1/2	32	40	43	54
-10	5/8	46	56	60	75
-12	3/4	65	80	90	110
-14	7/8	65	80	90	110
-16	1	92	105	125	240
-20	1-1/4	125	140	170	190
-24	1-1/2	150	180	200	245

DIN 24° Cone

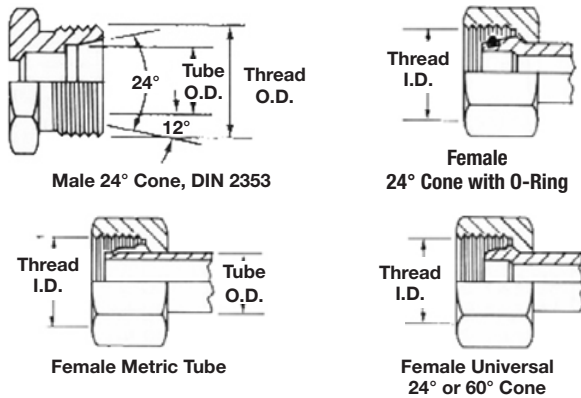

Tube O.D. (mm)		Ft.-Lbs.		Newton-Meters	
Light Series	Heavy Series	Min.	Max.	Min.	Max.
-6	—	7	15	10	20
-8	—	15	26	20	35
-10	-8	18	30	25	40
-12	-10	22	33	30	45
-14	-12	26	37	35	50
-15	-14	30	52	40	70
—	-16	30	52	40	70
-18	—	44	74	60	100
-22	-20	59	89	80	120
-28	-25	74	111	100	150
—	-30	74	162	150	220
-35	—	133	184	180	250
-42	-38	148	221	200	300

BSP 30° Inverted Cone

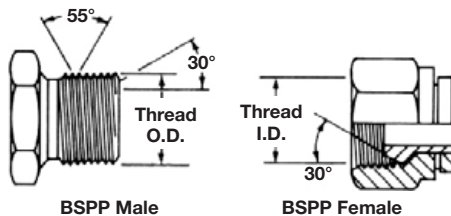

Size		Ft.-Lbs.		Newton-Meters	
Dash	Fractional (Inches)	Min.	Max.	Min.	Max.
		-4	1/4	11	13
-6	3/8	19	28	26	38
-8	1/2	30	36	41	49
-10	5/8	37	44	50	60
-12	3/4	50	60	68	81
-16	1	79	95	107	129
-20	1-1/4	127	152	172	206
-24	1-1/2	167	190	226	258
-32	2	262	314	355	428